



INSTALLATION INSTRUCTIONS FOR PART 87-99-3052

APPLICATIONS

CHEVROLET

Blazer 1973-1987

Pickup 1973-1987

GMC

Pickup 1973-1987

Suburban 1973-1987

87-99-3052

KIT FEATURES

- Shaft and DIN Unit Provisions

KIT COMPONENTS

A) Faceplate • B) Radio Housing

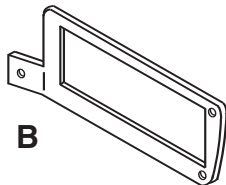
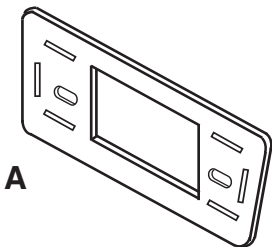

TOOLS REQUIRED:

- Phillips Screwdriver • Adjustable Wrench

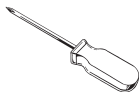

1-800-221-0932



www.metraonline.com

© COPYRIGHT 2001-2008 METRA ELECTRONICS CORPORATION



TABLE OF CONTENTS

Dash Disassembly - All Vehicles

CHEVROLET

Blazer 1973-1987 1

Pickup 1973-1987 1

GMC

Pickup 1973-1987 1

Suburban 1973-1987 1

Kit Assembly and Final Assembly

Shaft Head Unit Mount Radio Provision 1,2,3,4

DIN Head Unit Mount Radio Provision



KNOWLEDGE IS POWER

Enhance your installation and fabrication skills by enrolling in the most recognized and respected mobile electronics school in our industry.

Log onto www.installerinstitute.com or call 800-354-6782 for more information and take steps toward a better tomorrow.

ALL VEHICLES

Chevrolet - Blazer 1973-1987, Pickup 1973-1987

GMC - Pickup 1973-1987, Suburban 1973-1987

- 1 Disconnect the negative battery terminal to prevent an accidental short circuit. Remove (4) Phillips screws from the lower steering column panel and remove the panel. Remove (8) Phillips screws from the perimeter of the dash trim bezel and remove the bezel. Remove (3) Phillips screws securing the factory head unit and disconnect the wiring.

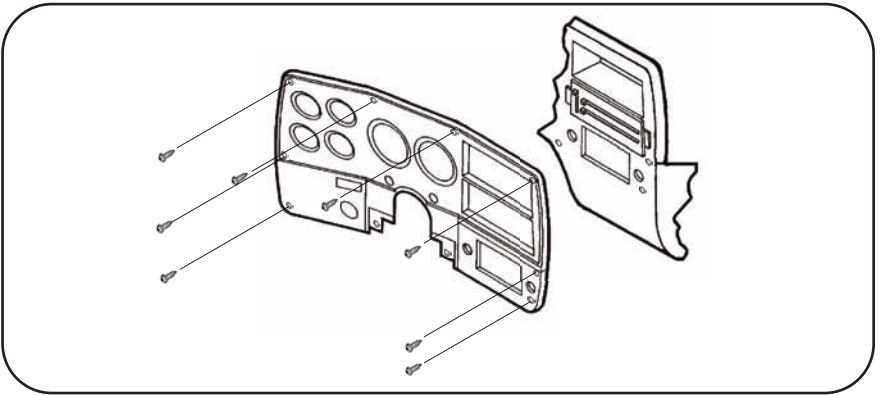

SHAFT HEAD UNITS: Position the Faceplate against the face of the radio trim bezel and slide it to the right until the right edge of the Faceplate meets the lip of the bezel. (see Fig. A). Slide the aftermarket head unit through the sub-dash, dash trim bezel and Faceplate and secure with shaft nuts. (see Fig. B). Skip to Final assembly.

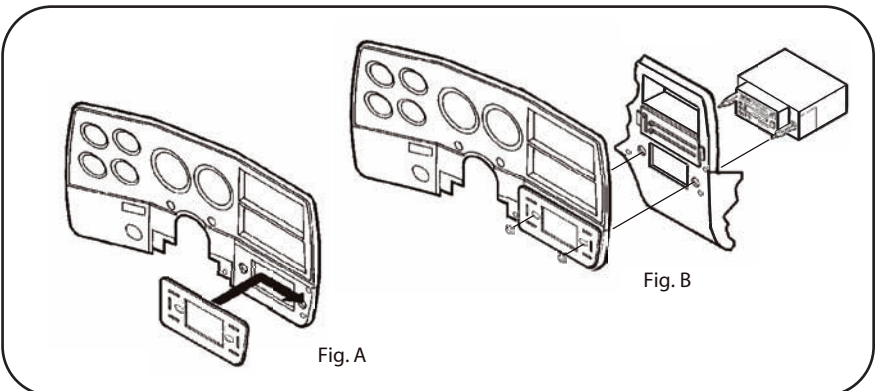

ALL VEHICLES

Chevrolet - Blazer 1973-1987, Pickup 1973-1987

GMC - Pickup 1973-1987, Suburban 1973-1987

- DIN HEAD UNITS:** Mount the Radio Housing to the sub-dash with (3) Phillips screws previously removed in step #1. (see Fig. A). Scribe the DIN radio opening onto the sub-dash metal, remove the Housing and cut the sub-dash along the scribed line. (see Fig. B). Place the Housing between the dash trim bezel and sub-dash and secure with the same (3) Phillips screws. (see Fig. C). Cut and remove the shaft supports from the Faceplate. Place the Faceplate against the face of the radio trim bezel and slide it to the right until the right edge of the Faceplate meets the lip of the bezel. (see Fig. D). Slide the DIN cage through the radio opening and secure by bending the metal locking tabs down. Slide the aftermarket head unit into the cage (see Fig. E) until secure.

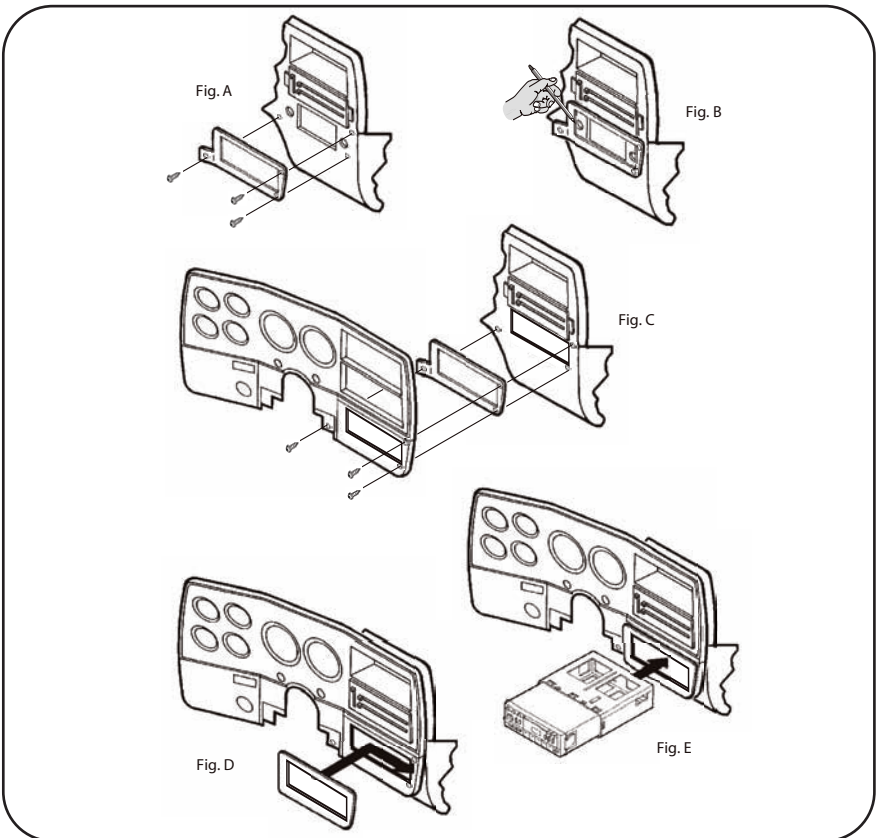

FINAL ASSEMBLY

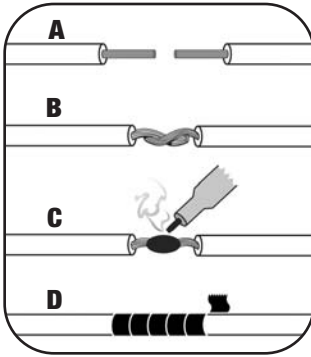

(A) Strip wire ends back 1/2"

B) Twist ends together

C) Solder

D) Tape

- 1** Locate the factory wiring harness in the dash. Metra recommends using the proper mating adapter and making connections as shown. (Isolate and individually tape off the ends of any unused wires to prevent electrical short circuit.)
- 2** Re-connect the negative battery terminal and test the unit for proper operation.
- 3** Reassemble radio and dash assemblies in reverse order of disassembly.

FINAL WIRING CONNECTIONS

Make wiring connections using the EIA color code chart shown below and the instructions included with the head unit. Metra recommends making connections as shown below; Strip, Splice, Solder, Tape. Isolate and individually tape off ends of any unused wires to prevent electrical short circuit.

METRA / EIA WIRING CODE

12V Ignition / Acc. Red	Right Front (+) Gray
12V Batt / Memory Yellow	Right Front (-) Gray / Black
Ground Black*	Left Front (+) White
Power Antenna Blue	Left Front (-) White / Black
Amp Turn-On Blue / White	Right Rear (+) Violet
Amp Ground Black / White	Right Rear (-) Violet / Black
Illumination Orange	Left Rear (+) Green
Dimmer Orange / White	Left Rear (-) Green / Black

***NOTE:** When a Black wire is not present, ground radio to vehicle chassis.
All colors may not be present on all leads due to manufacturer's specifications.

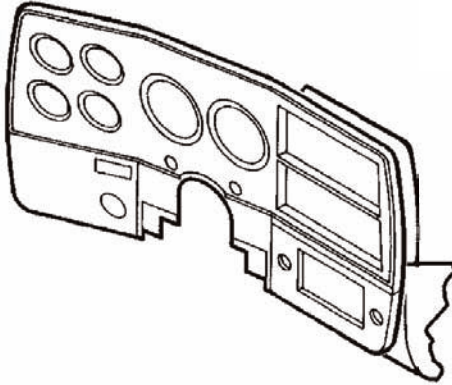
ALL VEHICLES**Chevrolet - Blazer 1973-1987, Pickup 1973-1987****GMC - Pickup 1973-1987, Suburban 1973-1987**

Re-connect the battery terminal and test the unit for proper operation. Locate the rear support provision in the sub-dash ("A").

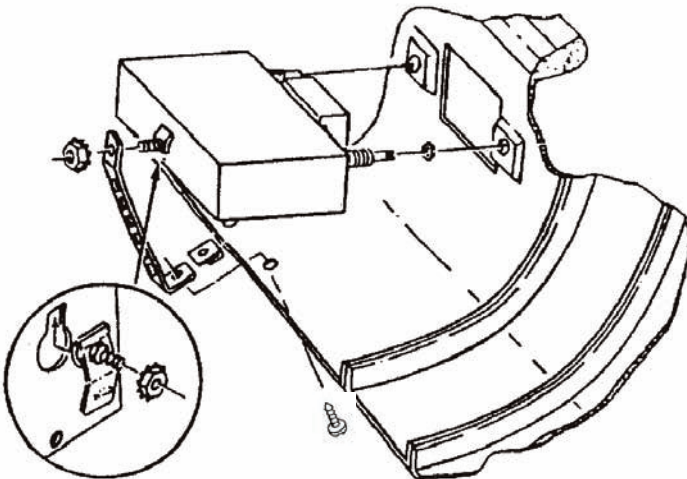

Using a perforated support strap, mount the back of the unit to sub-dash. the rear support location in the sub-dash.

87-99-3052 INSTRUCTIONS



1-800-221-0932



www.metraonline.com

REV. 11/06/08 © COPYRIGHT 2001-2008 METRA ELECTRONICS CORPORATION INST87-99-3052